

INSTRUCTIONS FOR OPERATING IMPERIAL EASTMAN NO. 364FHA AND 364FHAM LEVER TYPE TUBE BENDERS.

U.S. PAT. Nos. 2,887,917 and 3,665,335

This bender can be used for bending steel, stainless steel, copper, aluminum and other metal tubing of bending temper. Extremely thin walled and/or hard temper tubing should be avoided. (Type M tubing is not recommended for bending.)

BENDER SETUP

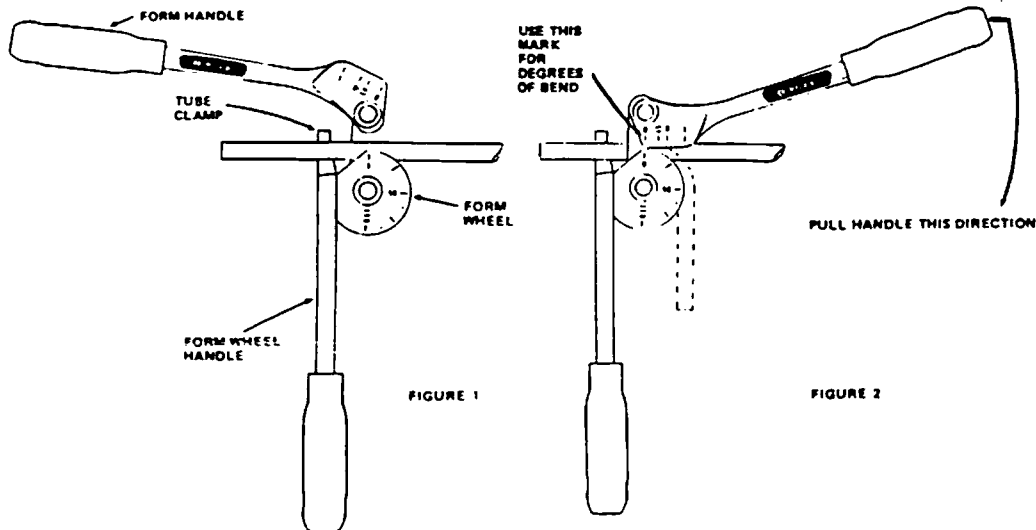

1. Raise form handle. (Fig. 1)
2. Position tubing in groove as shown. Also be sure that the tube is engaged with the tube clamp.
3. Lower the form handle to position shown. (Fig. 2)

4. Then pull lever handle in direction of arrow until the desired bend angle is obtained.
5. Degree of bend is indicated by mark on form handle and shown in Fig. 2. Bends up to 180° can be made in one sweep of the handle.

90° Bends

1. Measure from end of tube (first bend) and place mark on tubing.
2. Position tube in bender as shown in Fig. 3. If the end from which you measured is left of the tube clamp, the measured mark should be directly over graduation "L" located on the right side of the form lever and shown in Fig. 3.

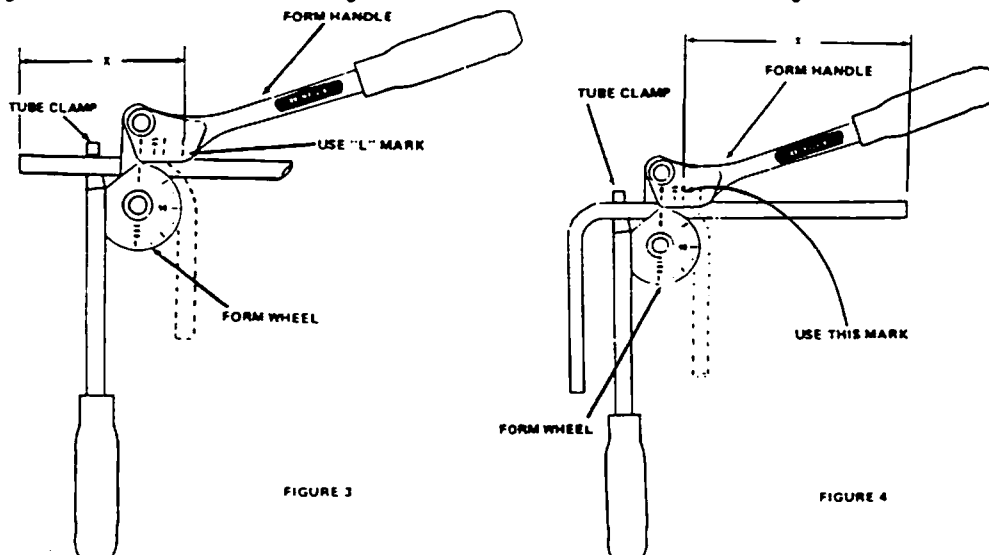

3. If the end from which you measured is placed to the right of the tube clamp, set the mark on the tube directly over graduation "R" located on the form lever and shown in Fig. 4. With a steady motion, pull form lever handle around until the "0" mark on form handle is directly opposite the 90° mark on form wheel.
4. If more than one bend is required (Fig. 5), measure from the center line of the first bend leg and mark per drawing dimension. Proceed with bend as described in Step 2.

SINGLE 45° BENDS

A single 45° bend may be made by measuring from end of tube to where bend is to be located and placing a mark at this point. Place tube in bender so that the mark on tube is

located directly in line with the "45" graduation on form handle shown in Fig. 6.

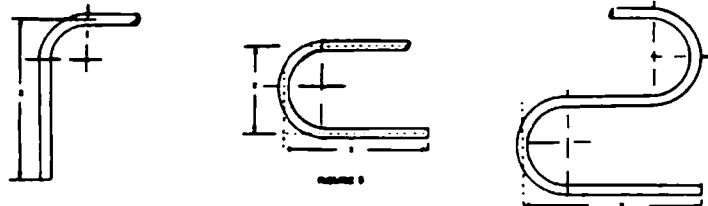

DOUBLE 45° or 30° OFFSET BENDS

When forming a tube offset, it is necessary to make two bends. It is important to mark the tube at both bend locations before proceeding. After marking the tube proceed as explained under "45° Bends".

4 EASY STEPS FOR FIGURING OFFSET BENDS

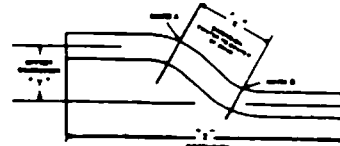
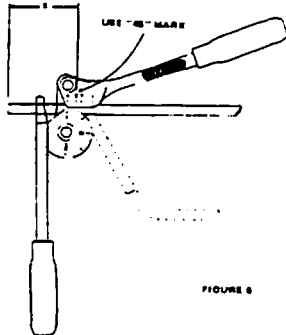

STEP 1 – Determine the total amount of offset required (dimension "Y" in diagram) and angle of offset. Wherever possible use 45° offset bends. This will enable you to figure the total amount of tubing required for a given application as explained in section on How to Figure Length of Tubing Required For 45° Offset Applications.

STEP 2 – Figure the length of tube which is needed to meet your offset requirements (X in dimension diagram) from table below. For example: Say the amount of offset you require ("Y" dimension, Step 1) is 2-1/2" and the offset angle is 45°. Check the 45° column and find 2-1/2". The figure next to this is the amount of tubing required for the offset bend you want ("X" dimension). In this case it's 3-17/32".

STEP 3 – Determine where you want the center of the offset bend on the tube and make a reference mark (A). Now measure off the "X" dimension (determined in Step 2, example 3-17/32") starting from the reference mark and make a second mark (B). You are now ready to make the bends.

STEP 4 – Align mark (A) with reference mark 45° on bender and proceed with first bend. Then align (B) with 45° mark and make second bend in proper direction.

NOTE: When the amount of offset exceeds what is listed on the table, choose an offset from the table which is a multiple of the offset you need. Look this up on the table and multiply the "X" dimension by the multiple you used. Example: For an offset of 20" for a 45° bend. Look up 5" offset on the table in the 45° column and multiply "X" dimension (7-1/16") by 4. The resulting "X" dimension you would use is 28-1/4".

OFFSET BEND CALCULATOR

| ANGLE OF OFFSET 30° | | ANGLE OF OFFSET 45° | | ANGLE OF OFFSET 30° | | ANGLE OF OFFSET 45° | |
|---------------------|---------------|---------------------|---------------|---------------------|---------------|---------------------|---------------|
| AMOUNT OF OFFSET | | AMOUNT OF OFFSET | | AMOUNT OF OFFSET | | AMOUNT OF OFFSET | |
| (Y Dimension) | (X Dimension) | (Y Dimension) | (X Dimension) | (Y Dimension) | (X Dimension) | (Y Dimension) | (X Dimension) |
| 1 | 2 | 1 | 1-13/32 | 3-5/8 | 7-1/4 | 3-5/8 | 5-1/8 |
| -1/8 | 2-1/4 | -1/8 | 1-19/32 | -3/4 | 7-1/2 | -3/4 | 5-1/16 |
| -1/4 | 2-1/2 | -1/4 | 1-25/32 | -7/8 | 7-3/4 | -7/8 | 5-15/32 |
| -3/8 | 2-3/4 | -3/8 | 1-15/16 | | | | |
| -1/2 | 3 | -1/2 | 2-1/8 | 4 | 8 | 4 | 5-21/32 |
| -5/8 | 3-1/4 | -5/8 | 2-5/16 | -1/8 | 8-1/4 | -1/8 | 5-27/32 |
| -3/4 | 3-1/2 | -3/4 | 2-15/32 | -1/4 | 8-1/2 | -1/4 | 6 |
| -7/8 | 3-3/4 | -7/8 | 2-21/32 | -3/8 | 8-3/4 | -3/8 | 6-3/16 |
| | | | | -1/2 | 9 | -1/2 | 6-3/8 |
| 2 | 4 | 2 | 2-13/16 | -5/8 | 9-1/4 | -5/8 | 6-17/32 |
| -1/8 | 4-1/4 | -1/8 | 3 | -3/4 | 9-1/2 | -3/4 | 6-23/32 |
| -1/4 | 4-1/2 | -1/4 | 3-3/16 | -7/8 | 9-3/4 | -7/8 | 6-29/32 |
| -3/8 | 4-3/4 | -3/8 | 3-11/32 | | | | |
| -1/2 | 5 | -1/2 | 3-17/32 | 5 | 10 | 5 | 7-1/16 |
| -5/8 | 5-1/4 | -5/8 | 3-23/32 | -1/8 | 10-1/4 | -1/8 | 7-1/4 |
| -3/4 | 5-1/2 | -3/4 | 3-7/8 | -1/4 | 10-1/2 | -1/4 | 7-7/16 |
| -7/8 | 5-3/4 | -7/8 | 4-1/16 | -3/8 | 10-3/4 | -3/8 | 7-19/32 |
| | | | | -1/2 | 11 | -1/2 | 7-25/32 |
| 3 | 6 | 3 | 4-1/4 | -5/8 | 11-1/4 | -5/8 | 7-31/32 |
| -1/8 | 6-1/4 | -1/8 | 4-13/32 | -3/4 | 11-1/2 | -3/4 | 8-1/8 |
| -1/4 | 6-1/2 | -1/4 | 4-19/32 | -7/8 | 11-3/4 | -7/8 | 8-5/16 |
| -3/8 | 6-3/4 | -3/8 | 4-25/32 | | | | |
| -1/2 | 7 | -1/2 | 4-15/16 | 6 | 12 | 6 | 8-15/32 |

NOTE: Keep bender bearings and form handle grooves lubricated. Keep oil away from form wheel grooves.

